

# Exploded view of general assembly and parts list

## ■ CABINET ASSEMBLY

Block No.M1MM

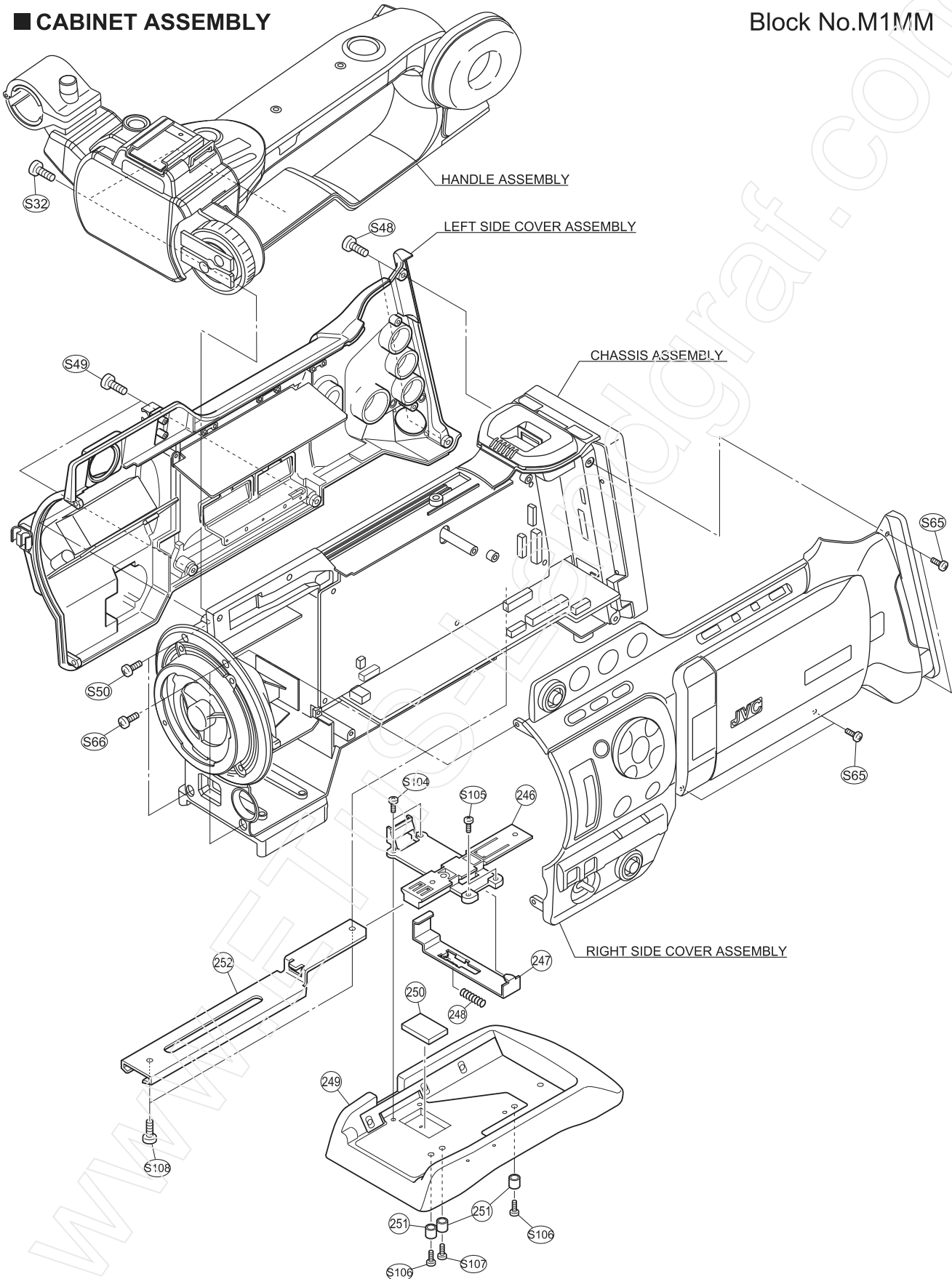

# CHASSIS ASSEMBLY

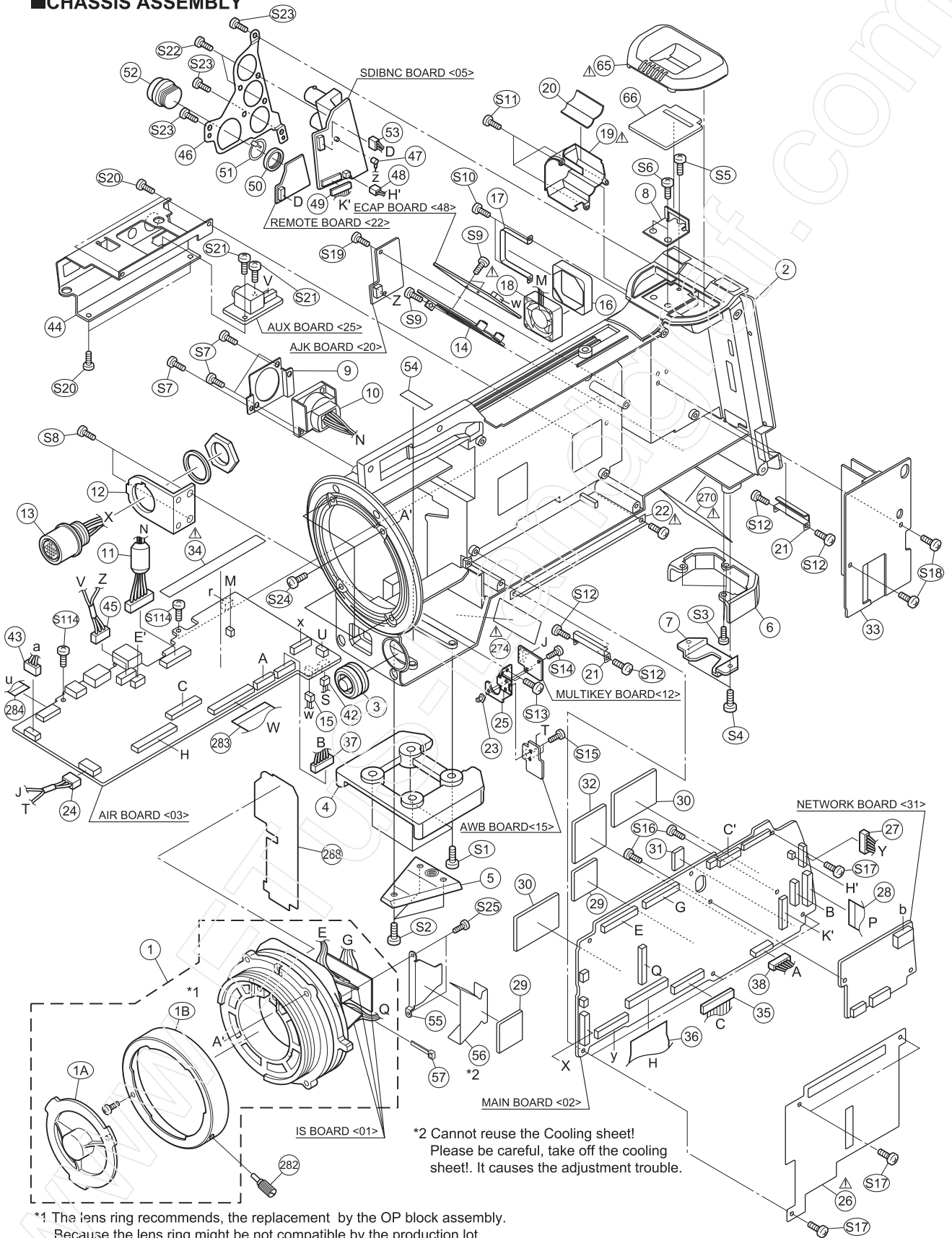

\*1 The lens ring recommends, the replacement by the OP block assembly. Because the lens ring might be not compatible by the production lot.

\*2 Cannot reuse the Cooling sheet! Please be careful, take off the cooling sheet!. It causes the adjustment trouble.

## ■ BATTERY MOUNT SECTION

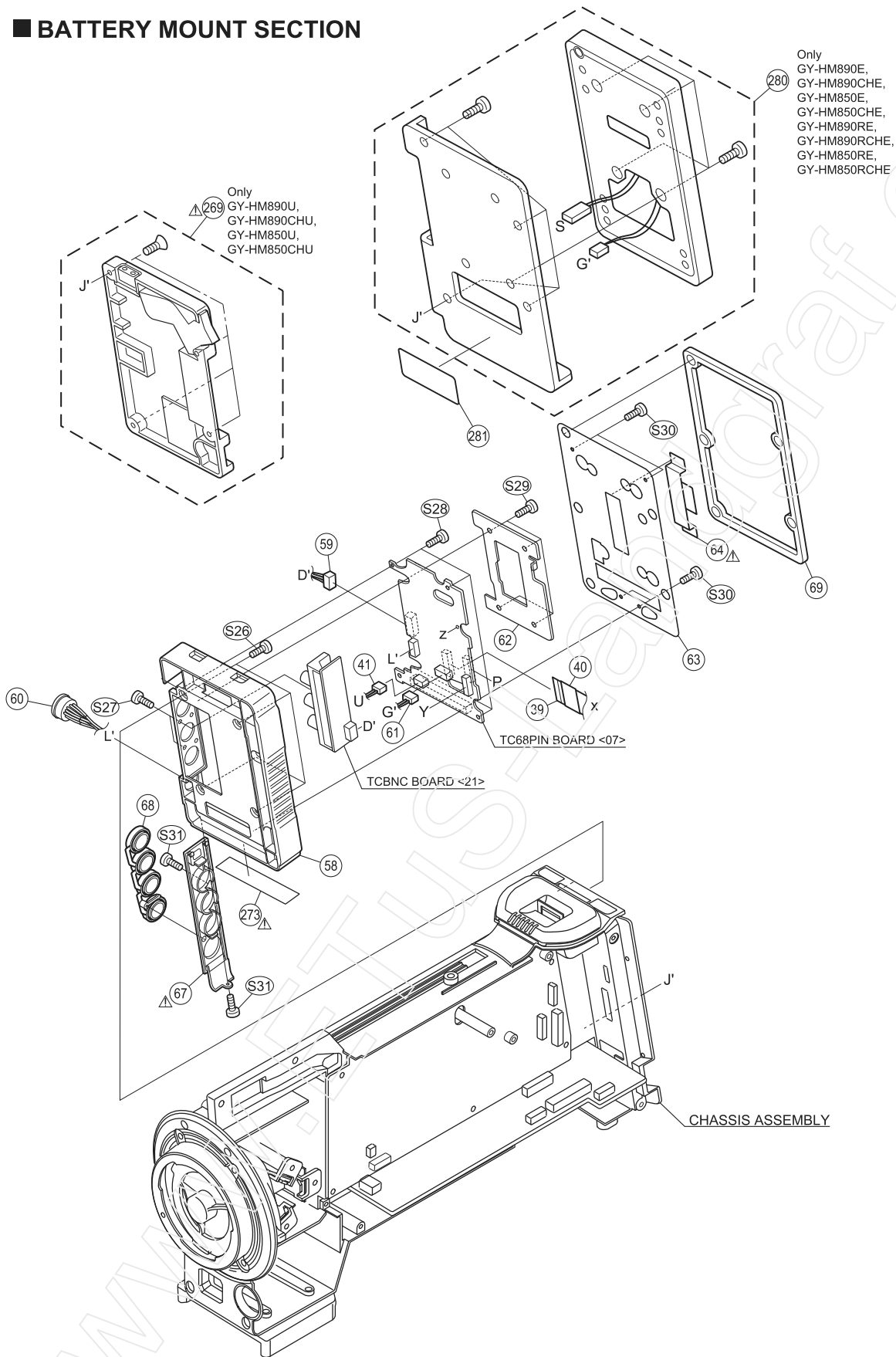

# RIGHT SIDE COVER ASSEMBLY

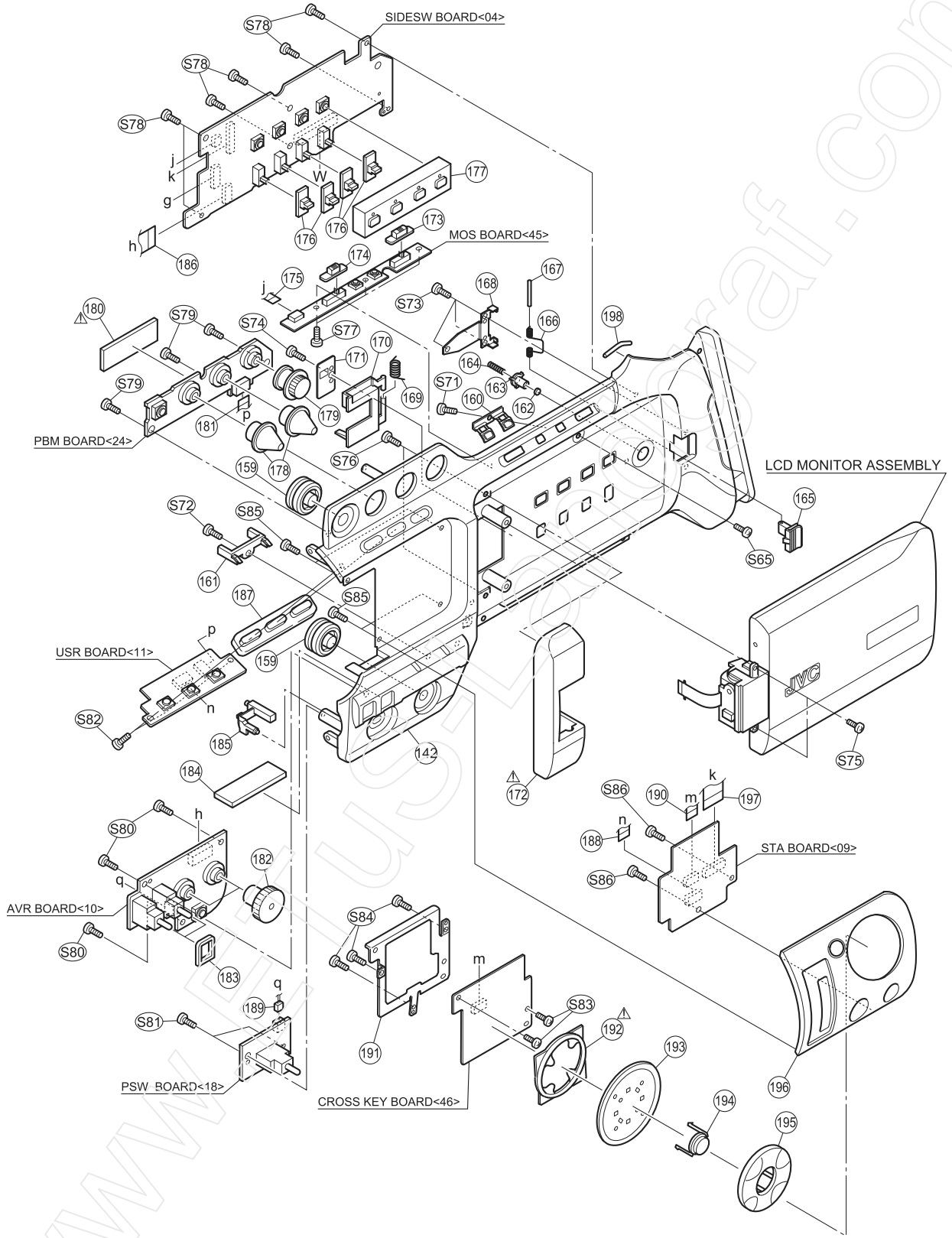

## ■ LCD MONITOR ASSEMBLY

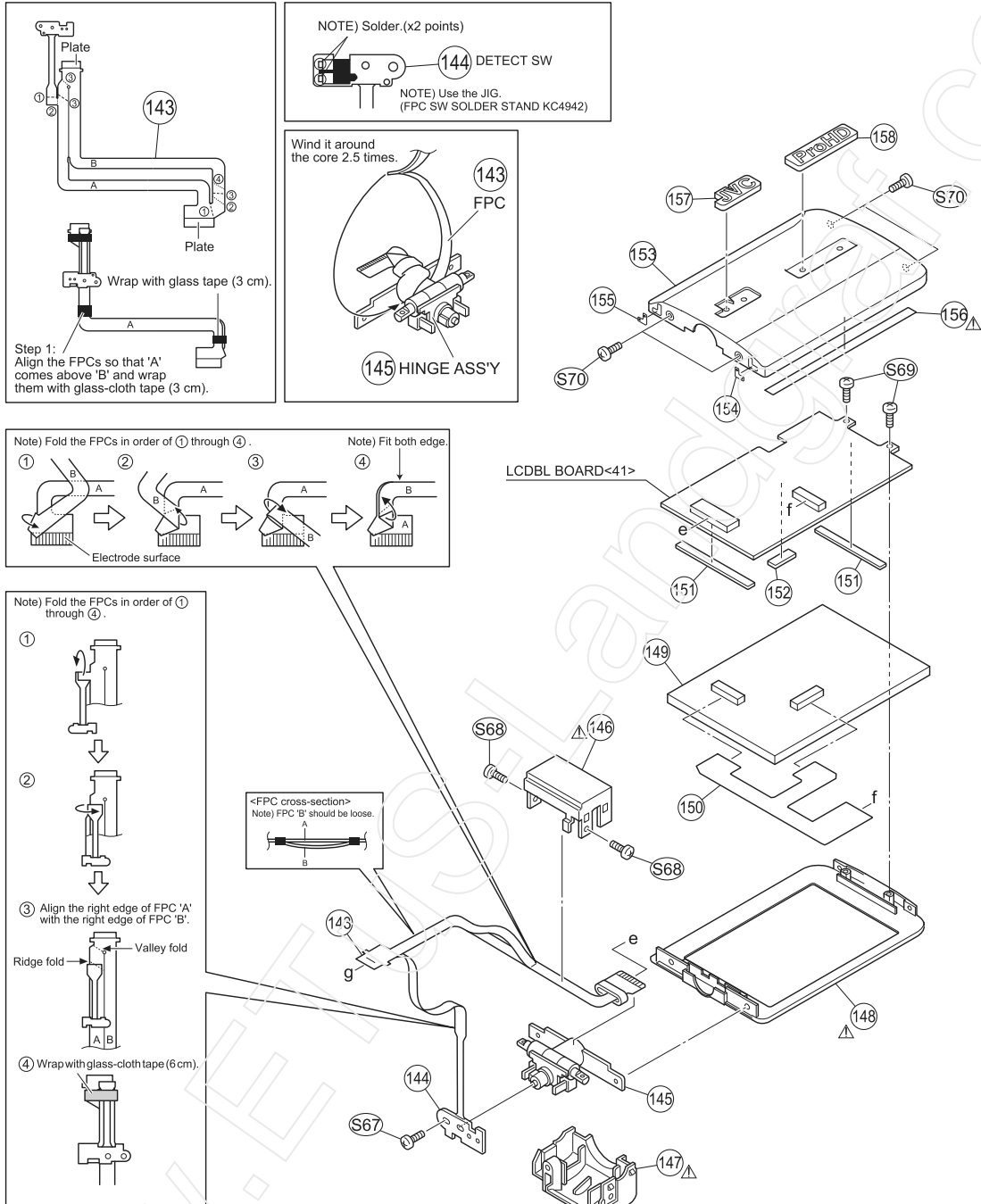

# LEFT SIDE COVER ASSEMBLY

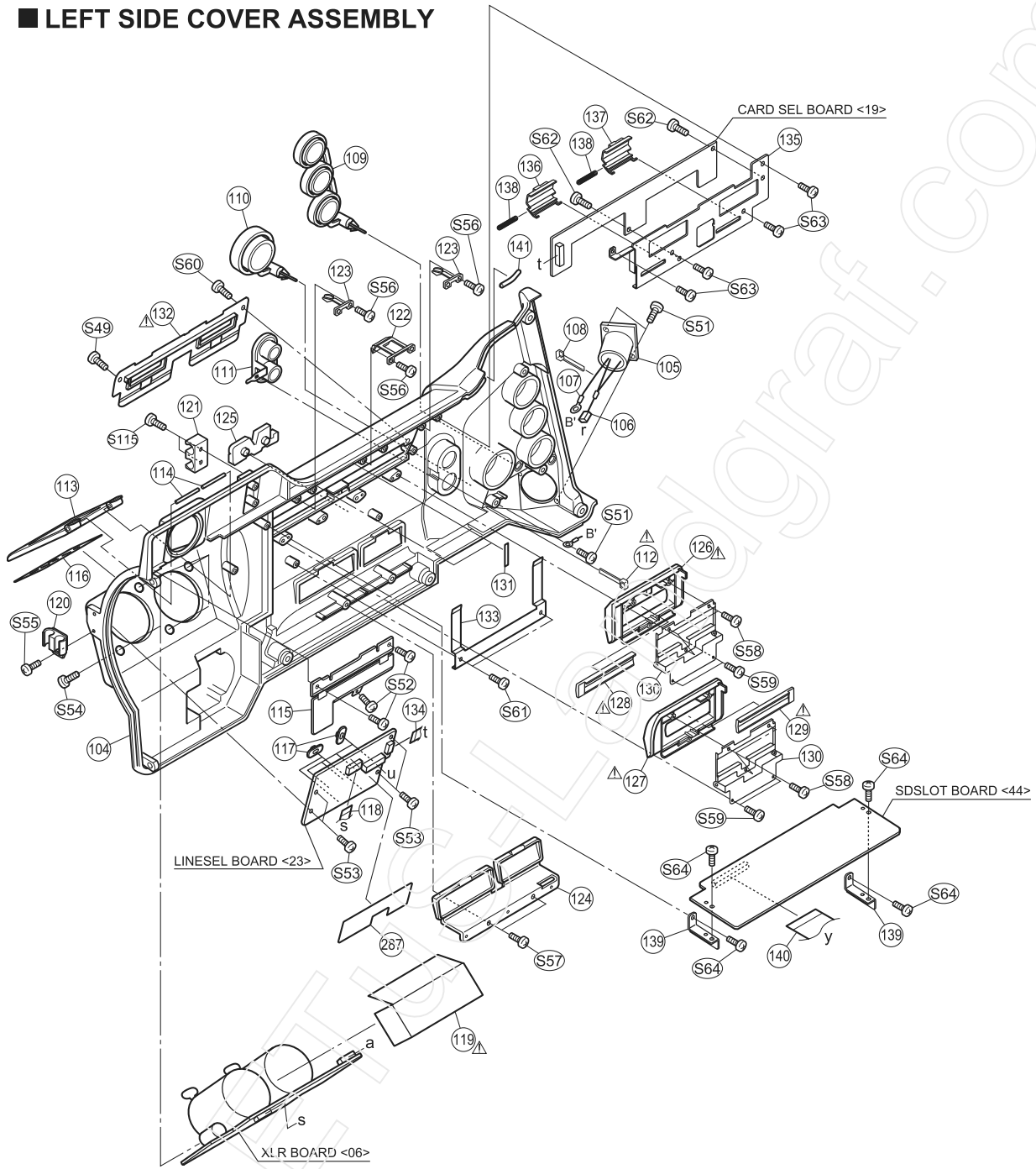

# ■ HANDLE ASSEMBLY

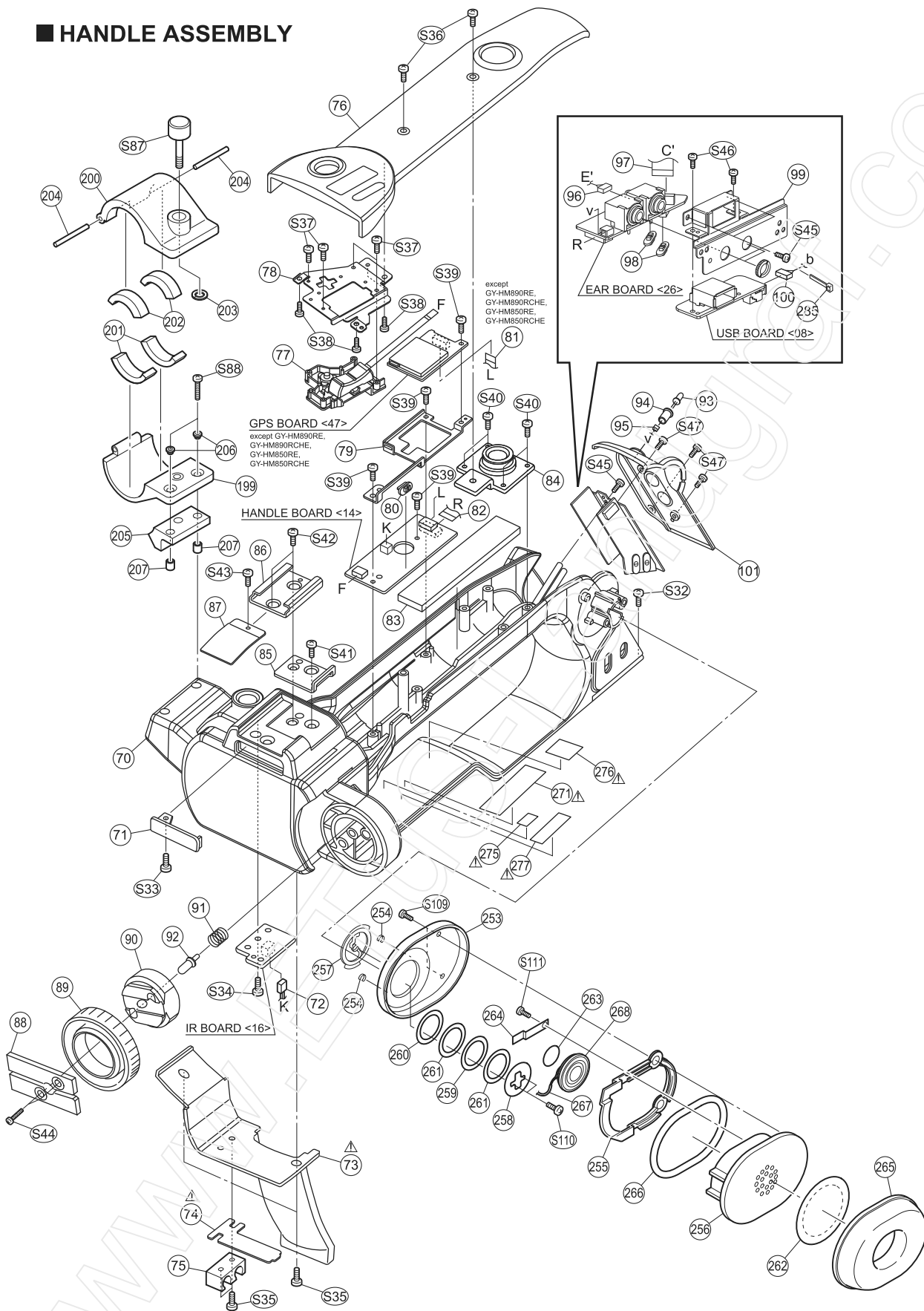

# VIEW FINDER ASSEMBLY

