

Exploded view of general assembly and parts list

■ CABINET ASSEMBLY

Block No.M1MM

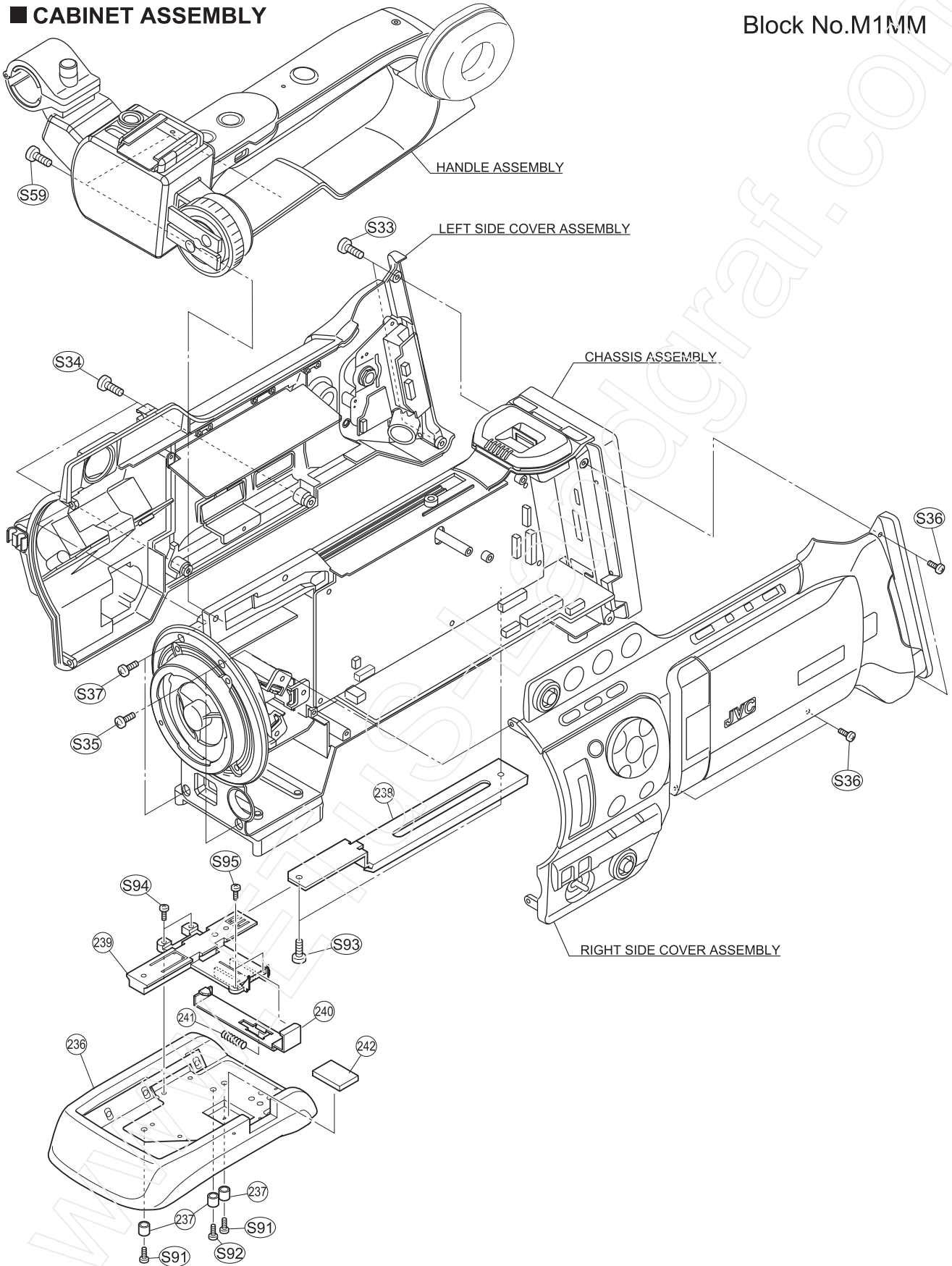

■ CHASSIS ASSEMBLY

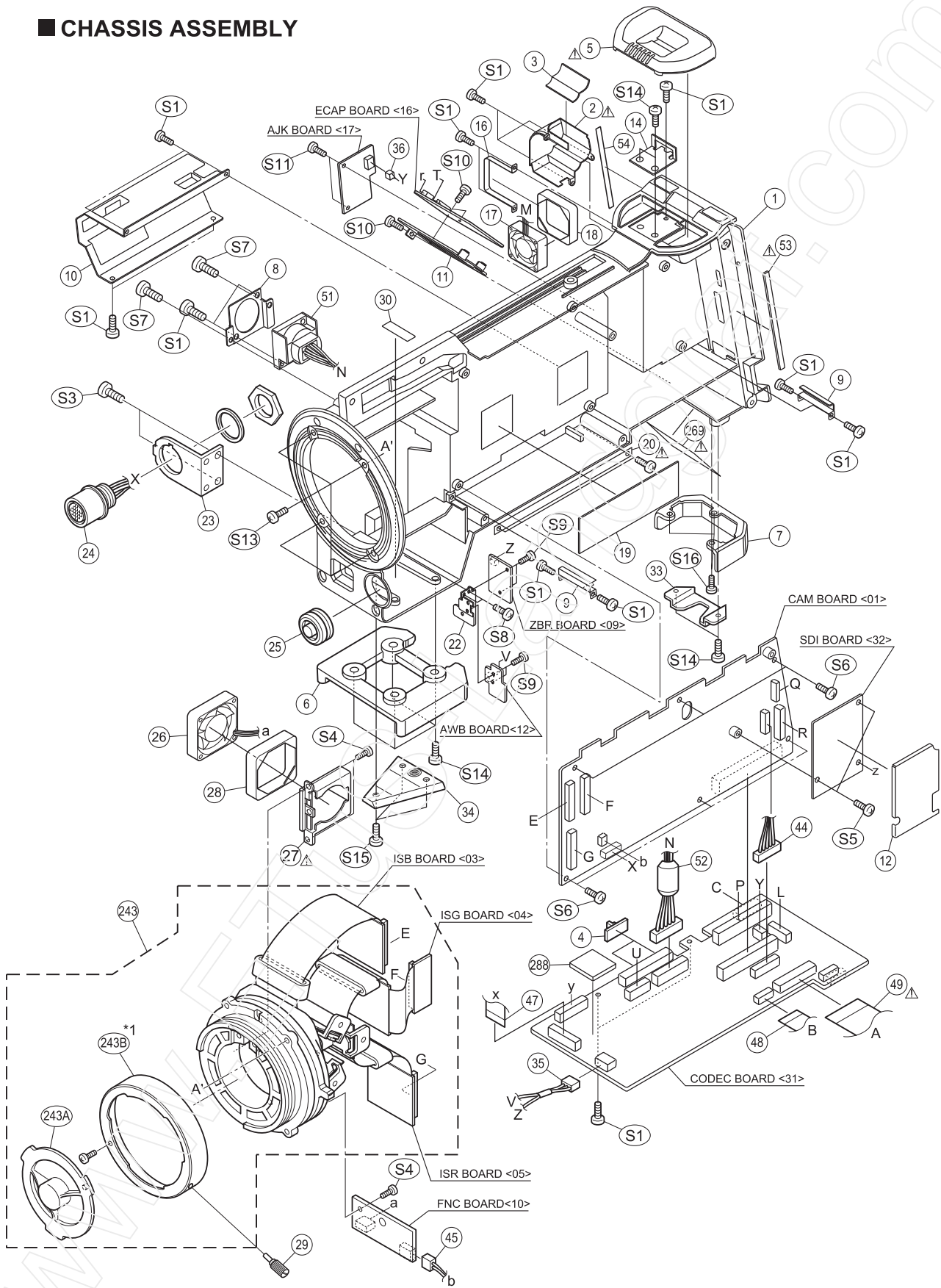

*1 The lens ring recommends, the replacement by the OP block assembly. Because the lens ring might be not compatible by the production lot.

■ BATTERY MOUNT SECTION

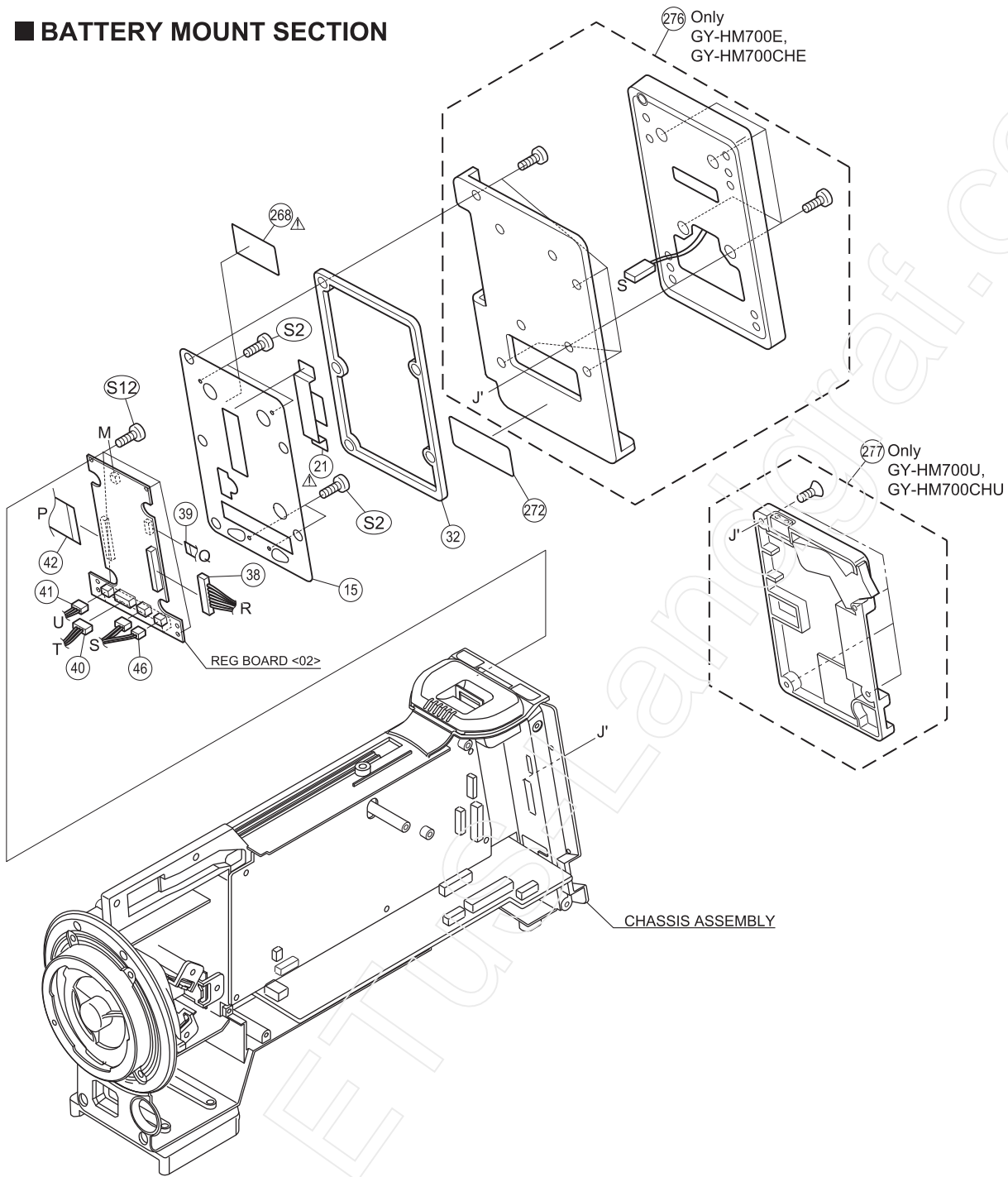

■ LCD MONITOR ASSEMBLY

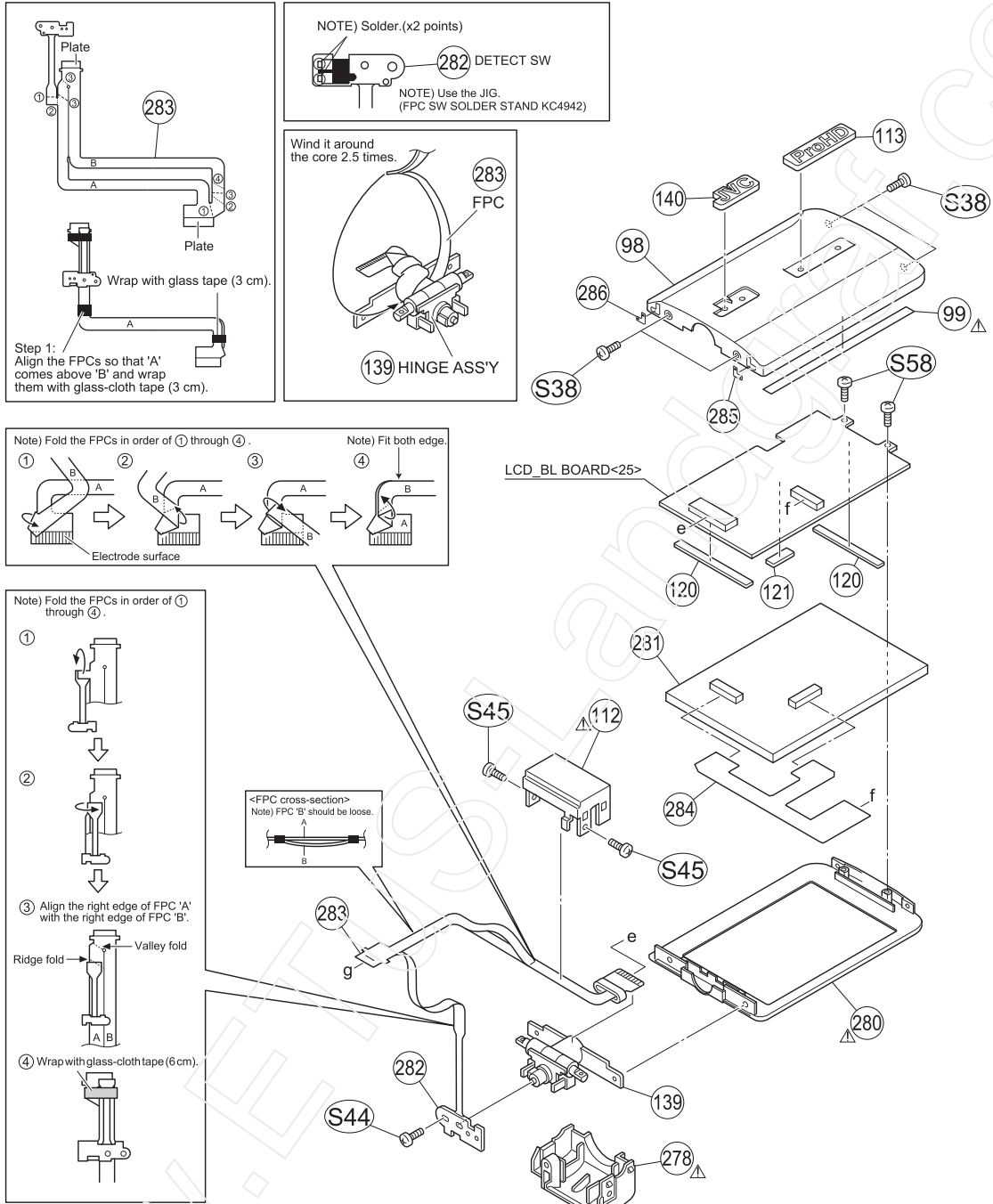

LEFT SIDE COVER ASSEMBLY

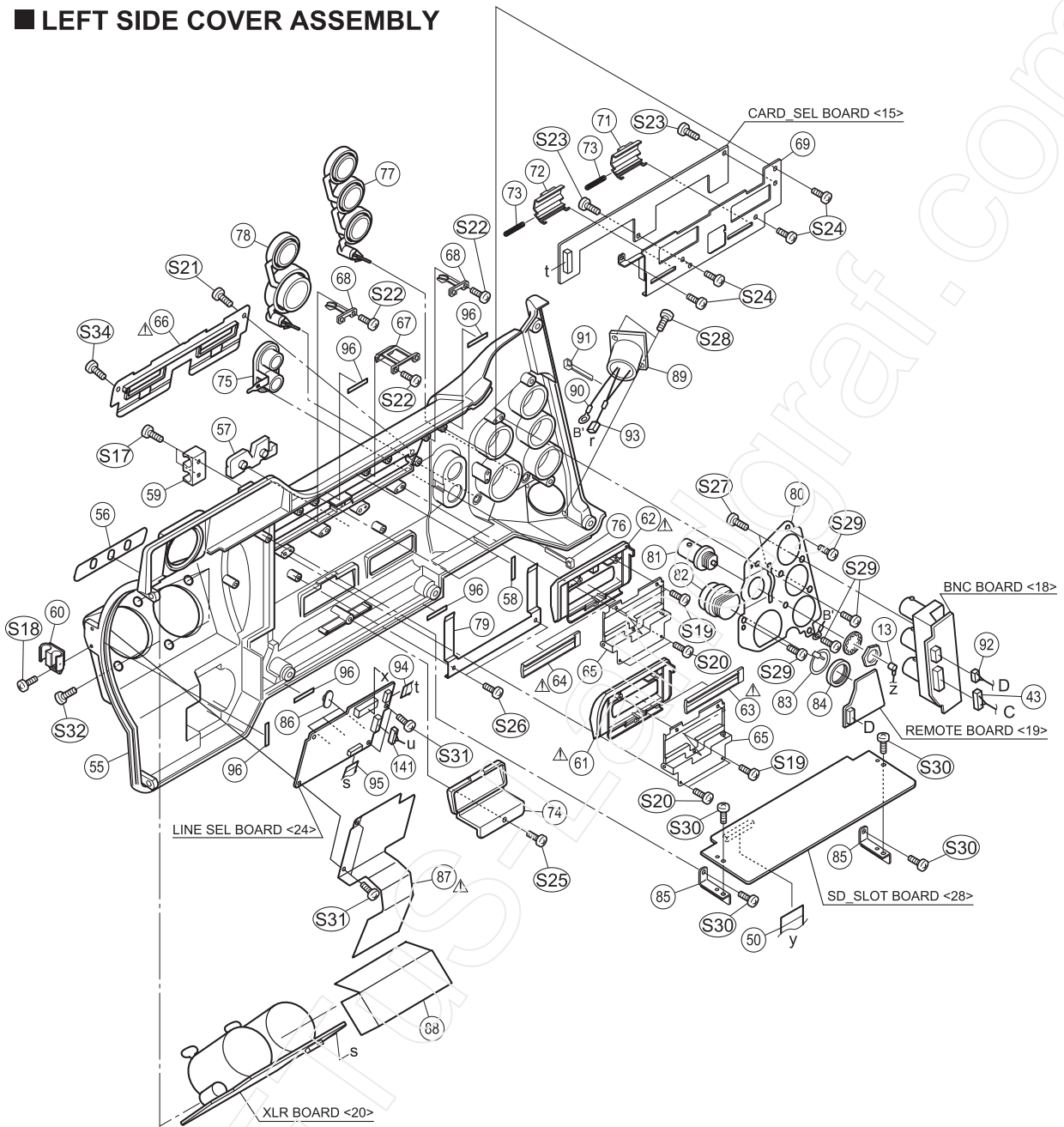

VIEW FINDER ASSEMBLY

